



# High Sierra Electronics

## Model 2400 Tipping Bucket Rain Gauge Top Section

1 mm and 0.01 inch Tipping Buckets

### Instruction Manual 60-2400-00(A)/-03(A)/-10(A)

#### TABLE OF CONTENTS

1.0	INTRODUCTION .....	1
1.2	Receiving, Inspection and Unpacking: .....	2
1.3	Specifications: .....	2
2.0	INSTALLATION .....	2
2.1	Installation Set-up: .....	2
2.2	Base Section to Standpipe: .....	3
2.3	Leveling: .....	3
2.4	Testing and Final Assembly: .....	3
3.0	OPERATION .....	3
4.0	MAINTENANCE .....	3
4.1	Special equipment needed: .....	3
4.2	Standard Maintenance: .....	3
4.3	Field Calibration check: .....	4
5.0	TROUBLESHOOTING .....	4
6.0	RETURNS .....	5
7.0	WARRANTY .....	5
8.0	APPENDIX .....	6
8.1	2400 Block Diagram: .....	6
8.2	Tipping Bucket Mechanism .....	7
8.3	Field Calibration .....	8

## 1.0 INTRODUCTION

### 1.1 General Description:

The Model 2400 Tipping Bucket Rain Gauge Top Section is made of a powder coated 12" diameter aluminum tube with locking mechanism and a base section with 1 3/8" access tube and leveling base plate. The base section can be either a roof mount option or for standpipe applications. Depending on the standpipe configuration, this can be either slotted or with a locking mechanism. An anodized aluminum funnel with insect screens is mounted in the top of the 12" diameter tube.

A Model 2400-3 Tipping Bucket with a magnetically operated sealed reed switch provides a reliable normally open, momentary switch closure for transmission by a 3200 Series ALERT Data Transmitter. It is made of anodized aluminum with a one-piece

machined aluminum tipping bucket. A bull's-eye level is provided for leveling at the installation site.

### 1.2 Receiving, Inspection and Unpacking:

Many *High Sierra Electronics* products are scientific instruments. Exercise care during unpacking and installation. Remove the contents of the package carefully and compare the contents with the enclosed packing list. Should any items be missing, notify *High Sierra Electronics* Customer Service. Please have your packing list available when you call.

If any of the items are received in damaged condition, notify the carrier immediately and request an inspection. You must notify the carrier within 15 days of shipment. If a claim is not made within that time period, then the carrier will not acknowledge any claim for the lost or damaged goods.

#### 1.2.1 Special inspection instructions:

Remove the rubber band securing the bucket of the tipping bucket assembly. Inspect the tipping bucket magnet arm to insure that the magnet passes freely past the reed switch (see **Appendix 8.2**). If the magnet drags, see section **4.0 Maintenance** for instructions to correct this problem. Replace the rubber band before transporting the assembly to the installation site.

### 1.3 Specifications:

#### Tipping Bucket:

Calibration:	2400-03, 1 mm/Tip
Optional:	2400-10, 0.01 in/Tip
Accuracy:	± 1.5% for Precipitation Rates from 0-150 mm/Hour
Output:	Normally Open Momentary Contact
Optional:	Form C, Three wire switch

#### Top Section:

Dimensions:	12" Diameter x 23" High
Shipping Weight:	13 Lbs. with tipping bucket

## **2.0 INSTALLATION**

### 2.1 Installation Set-up:

Unlock the Upper Tube from the base section, rotate clockwise and lift up to remove from the base section. Set the Upper Tube aside. Remove the rubber band that keeps the tipping bucket from moving (during shipping) and verify that the bucket can now move freely between the calibration screws. The sensor cable is now routed through the 1 3/8" tube and out the bottom.

To install the 2400-3 Tipping Bucket on an existing base section, place the 2400-3 Tipping Bucket Mechanism on the base section mounting plate, over the three 1/4-20 mounting studs. The correct sequence for the hardware (starting from the bottom) is as

follows: (a) leveling spring, (b) 2400-3 Rain Gauge, (c) ¼ SS flat washer, and (d) ¼-20 SS nut.

#### 2.2 Base Section to Standpipe:

The sensor cable is dropped into the standpipe and the base section is set in place on the standpipe. Rotate the base section counter clockwise and lock in place. If using a slotted base section, align the slots with the nutters in the standpipe and secure with the four 10-32 button head screws.

#### 2.3 Leveling:

The Model 2400-3 Tipping Bucket sits on spring loaded mounting studs. To level, adjust the ¼-20 SS nuts such that the air bubble in the bull's-eye level is within the centering circle.

#### 2.4 Testing and Final Assembly:

Plug the Model 2400-3 into the data telemetry system (either data logger or transmitter) and tip the bucket for a ten (10) count. Verify either collection of data or transmission of data. If Tipping Bucket tests O.K., reset the accumulator value to zero. Replace the Upper Tube onto the base section; rotate counter clockwise and lock in place.

### **3.0 OPERATION**

The operation of the Model 2400-3 Tipping Bucket is completely automatic and requires no supervision when properly installed. It has been calibrated at the factory and another calibration is only essential if the gauge has been damaged during shipping, installation or through vandalism. It has been found that a clean bucket is a calibrated bucket and field calibration is seldom, if ever, needed.

If your Model 2400-3 has been in the field for a while and has collected a coating of dirt, a good bath will free up any dragging of the bearings and bring the bucket assembly back into balance. Tipping buckets can be out of calibration due to dragging bearings or increased weight of the bucket. No adjustments are necessary, just cleaning.

### **4.0 MAINTENANCE**

#### 4.1 Special equipment needed:

- 1/4 and 1/2 inch Bottle brushes and scrub brush
- Mild detergent or other cleaning solution and Clean rags
- Ohm meter
- Graduated cylinder and/or calibration bottle (if checking the calibration)

#### 4.2 Standard Maintenance:

The Model 2400 should be serviced at a minimum of once per year. In areas that have a very large insect population, a more aggressive and frequent maintenance program may be needed to prevent insects from clogging up the drain holes.

During the maintenance visit to the site, use the following checklist:

1. Clean dirt/debris from funnel and funnel tube.
2. Clean dirt/debris from Tipping Bucket
3. Check switch operation:

The tipping bucket shaft should have 0.030 - 0.050 inches of free play. The magnet arm should freely pass the reed switch. There should be at least .005" clearance between the magnet and the reed switch when the shaft with magnet arm is shifted towards the magnet. If the magnet is too close to the reed switch, carefully bend the arm until there is sufficient clearance.

When the bucket is resting on the acorn nuts, your ohmmeter will read infinite resistance. As the magnet passes over the switch, the resistance of the contacts should be less than 1 Ohm. Be certain that when the shaft is shifted away from the reed switch there is still switch closure.

4. Check All Cables & Connectors
5. Check Enclosures for Leaks, Insects, Spider Webs, etc.
6. Check for Physical Damage

The rim of the funnel should be round, as any dents could affect the accuracy of the gauge. Bullets and other penetrating objects will affect operations and/or destroy the tipping bucket mechanism.

#### 4.3 Field Calibration check:

It is recommended that every two years a calibration check be performed on the tipping bucket. If extra tipping buckets are available a rotation schedule may be established. The tipping buckets to be checked may be returned to *High Sierra Electronics* for the calibration check, or the calibration check may be done by maintenance personnel at the shop. If no replacement buckets are available a simple field calibration is described in appendix 8.3.

## **5.0 TROUBLESHOOTING**

If the Model 2400-3 Tipping Bucket Rain Gauge does not perform to specification, a careful procedure should be followed to ascertain the problem. It should be noted that the majority of failures are due to bad connections.

1. Check the M/S connector for signs of corrosion and clean as needed, this includes the connector on the transmitter.

2. Check the magnet (under the heat shrink on the brass arm) for magnetic properties using a ferrous (iron/steel) metal. A weak magnet will only operate the switch if it is right next to the switch housing, but this causes drag and affects the calibration and should be returned to the factory to be rebuilt and calibrated.

3. If the magnet is good, then an Ohmmeter placed between pin A and pin D (M/S connector) can verify the reed switch operation.

4. If physical damage has occurred to the Model 2400-3, it should be returned to the factory to be rebuilt (if possible) and calibrated. Call *High Sierra Electronics* for prices and availability of a loaner Model 2400-3.

For technical assistance with this product, consult *High Sierra Electronics* technical personnel at: Phone: 1-800-275 2080 or FAX 1-530-273-2089 between 8:00 AM and 5:00 PM Pacific Coast time, Monday thru Friday. To e-mail: [info@highsierraelectronics.com](mailto:info@highsierraelectronics.com).

## 6.0 RETURNS

If you need to return this product for any reason, call *High Sierra Electronics* at (530) 273-2080 between 8:00 a.m. and 4:00 p.m. Pacific Coast time. Ask for a return Authorization Number (RA#) to be assigned to your unit. Carefully pack the unit, using a rubber band to hold the tipping bucket in place, so that it will not be further damaged in shipment. Write the RA# on the outside of the box and on any paperwork enclosed with the unit. Please include a written description of the problem and any unique conditions that occurred when the unit failed.

## 7.0 WARRANTY

All *High Sierra Electronics*' manufactured products are warranted against defects in materials and workmanship for a period of three (3) years from the date of shipment. If the equipment fails due to such defects, *High Sierra Electronics* will, as its option, repair or provide a replacement for the defective part or product. In no case will *High Sierra Electronics* be liable for more than the original purchase price.

Equipment supplied by *High Sierra Electronics* and manufactured by others, carries the respective manufacturer's warranty. *High Sierra Electronics* assumes no warranty obligation, either express or implied, for equipment manufactured by others and supplied by *High Sierra Electronics*.

*THIS WARRANTY IS IN LIEU OF ALL OTHER WARRANTIES, EXPRESSED OR IMPLIED, INCLUDING, WITHOUT LIMITATION, ANY IMPLIED WARRANTY OF MERCHANT ABILITY OR FITNESS FOR A PARTICULAR PURPOSE, ALL OF WHICH IS EXPRESSLY DISCLAIMED.*



***High Sierra Electronics***

13355 Grass Valley Avenue  
Grass Valley, CA 95945

Phone: (530) 273-2080  
Fax: (530) 273-2089

REVISIONS			
REV NO	ECO NO	DESCRIPTION	DATE
A		RELEASED	02-11-04

FIGURE 1, TOP SECTION

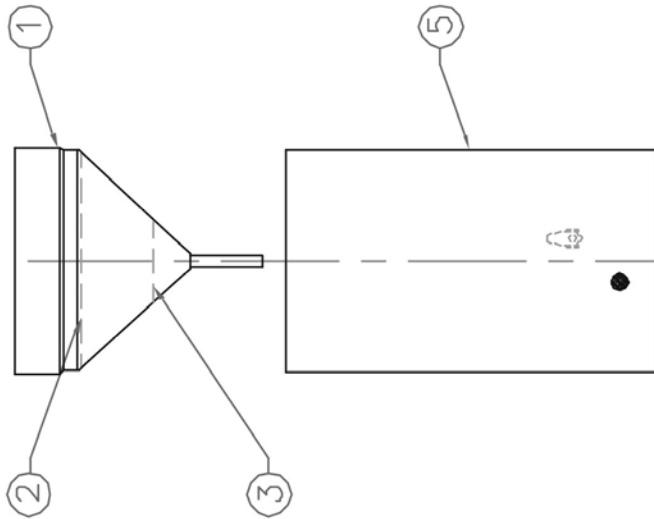

TOP VIEW  
(FUNNEL REMOVED)

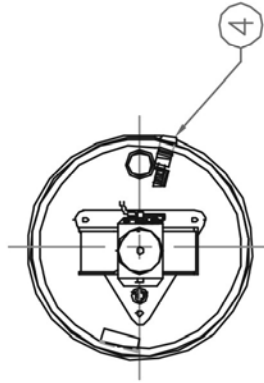

PARTS:

1. FUNNEL ASSY
2. OUTER FUNNEL SCREEN
3. INNER FUNNEL SCREEN
4. LOCK ASSY
5. UPPER TUBE
7. STRIKER ASSY
8. SPUN SHELF ASSY (WITH TIPPING BUCKET MOUNTING PLATE)
10. TIPPING BUCKET

FIG.2, TIPPING BUCKET ASSY.

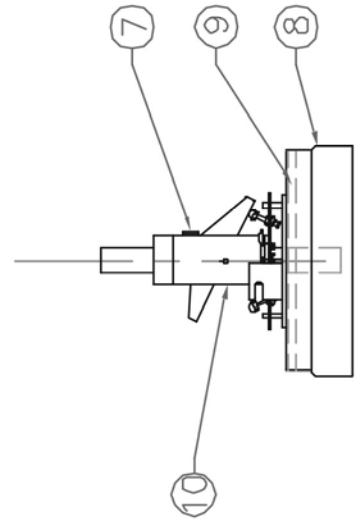

**High Sierra Electronics**  
GRASS VALLEY, CALIFORNIA

TITLE:		MODEL 2400/TOPSECTION	
N.H.A.:		DWG. NO.: 61-2400-81	
DRAWN BY:	DATE:	APPROVED BY:	
JEANIE ALVEY	02-11-04		
SIZE:	SCALE:	SHT. NO.:	
A	1:1	1 OF 1	

61-2400-00A

TIPPING BUCKET ASSEMBLY

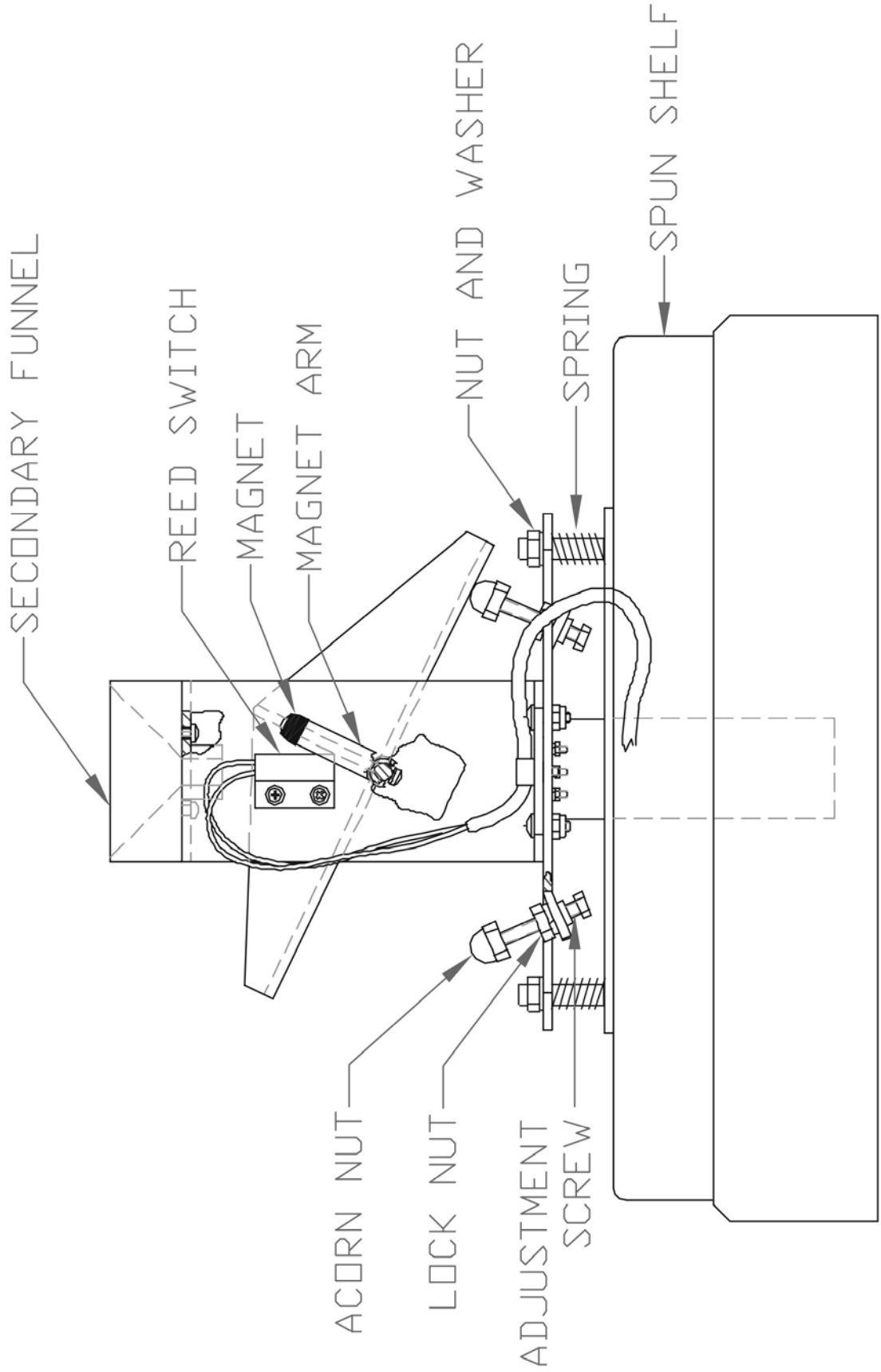

## 8.2 Tipping Bucket Mechanism

### 8.3 Field Calibration

#### 8.3.1 equipment needed:

Calibration Bottle  
100ml Graduated Cylinder  
10ml Graduated Cylinder  
Eye Dropper or Syringe

#### 8.3.2 Simple Calibration bottle

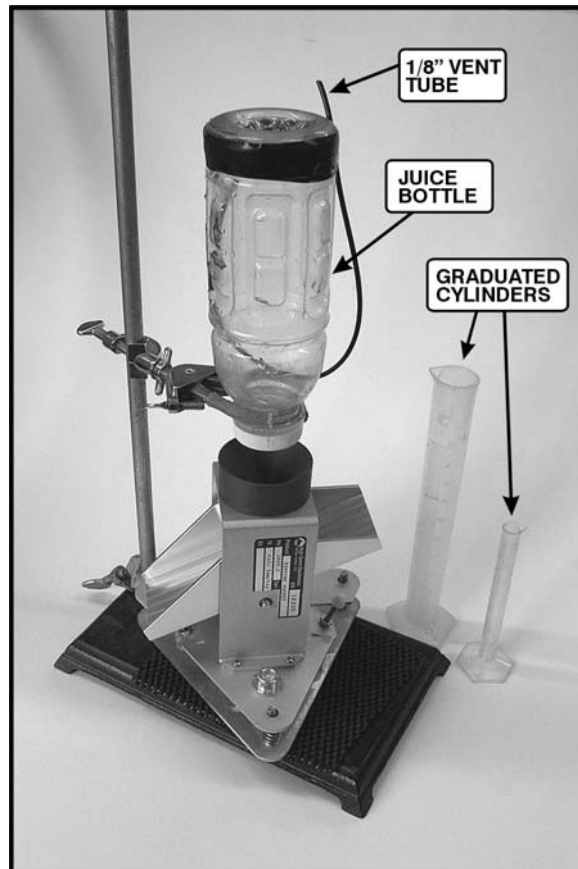

A simple calibration bottle may be made from a plastic water or juice bottle. Drill a hole near the top (the natural top) of the bottle and insert a vent tube in the bottle. The vent tube should form a 'U' with the inside leg not quite touching the bottle bottom and the outside leg protruding an inch or more above the bottom of the bottle. Secure the outside leg of the vent tube to the bottle with water resistant tape. Place a bead of silicone caulking at the vent tube opening. Drill two or three 1/16 inch holes in the bottle top. Using the 100ml and 10ml graduated cylinders, carefully measure the desired volume of water and fill the bottle. Mark the water level with water resistant ink. It is best to perform this initial calibration a couple of times to be certain that the calibration is consistent.

A single calibration check using the calibration bottle described above should take about 15 minutes. Note: After filling the bottle and inverting it, gently blow through the vent tube to free any water trapped in the tube. If the flow appears

restricted during the calibration check, blow gently through the tube to restore normal flow. It should be noted that the flow will slow as the water level decreases. At the beginning of the test there will be about 1.5 minutes between tips. The last tip may take 4 minutes or longer. Gently blowing through the vent tube while the bucket is filling can decrease the calibration check time required. Try to let the natural flow occur when the bucket is almost full and ready to tip. Be careful not to disturb the mechanism if this method is used.

The picture shown above uses a stand for holding the water bottle and a baseplate for leveling the tipping bucket. In the field, the top section base may be used to hold the tipping bucket and the top section and funnel, loosely set over the base used to hold the water bottle.

### 8.3.3 1 mm tipping bucket calibration check:

Separate the top section from the spun shelf assembly of the Model 2400 Rain gauge. Remove the spun shelf assembly from the standpipe. (The tipping bucket may be calibrated in place on the standpipe, but for ease of access on tall standpipes, it might be best to remove the entire top section.

Place spun shelf assembly on a level platform and level the tipping bucket by adjusting the 3 adjusting screws on the spun shelf assembly. Connect the signal cable to either the data transmitter or a digital counter (you may also just watch and count the tips).

With the graduated cylinders, accurately measure 605 ml of clean water and fill the calibration bottle (or fill to the calibration mark on the bottle). Gradually pour the water from the calibration bottle through the secondary funnel. If not using a slow delivery water bottle such as described above, do not pour at a rate faster than 20 seconds per tip (1mm tipping bucket). You may fill most of the bucket faster, but the rate should be slow as the bucket tips. With 605 ml. of water the bucket should tip 8 times with 21 ml of water remaining. If after eight tips, the volume of water remaining in the bucket (or bottle) is between zero and 40 ml. of water the tipping bucket may be considered within tolerance (this is a three percent tolerance). After the eighth tip the remainder of water in the calibration bottle may be measured rather than run through the tipping bucket. Measure the water remaining with one of the graduated cylinders. If the tipping bucket calibration check falls outside of a tolerance that is acceptable, the field test should be run again. If a second test confirms that the tipping bucket is out of tolerance the tipping bucket should be returned to *High Sierra Electronics* for re-calibration. Field adjustment of the calibration is not recommended.

Example:

Volume of water/72.97=Number of tips expected + remainder.

$$605/72.97 = 8.291\text{tips}$$

Remainder x 72.97= remainder in ml.

$$0.291 \times 72.97 = 21 \text{ ml}$$

Tolerance with 3% error acceptable = volume introduced x .03

$$605 \times 0.03 = \pm 18\text{ml}$$

8.3.4 0.01 inch tipping bucket calibration check:

Follow the directions in section 8.3.3. The Volume of water placed in the calibration bottle may be reduced to 306 milliliters. The bucket should tip 16 times with 9.5ml remaining. An acceptable range is no water in the bucket after 16 tips, or the bucket just tips for a 17th time.

Example:

Volume of water/18.53=Number of tips expected + remainder.

$$306/18.53 = 16.514 \text{ tips}$$

Remainder x 18.53 = remainder in ml.

$$0.514 \times 18.53 = 9.5 \text{ ml}$$

Tolerance with 3% error acceptable = volume introduced x .03

$$306 \times 0.03 = \pm 9\text{ml}$$